

# **SESSION - 2**

**IN : INSTRUMENTATION ENGINEERING***Duration:* Three Hours*Maximum Marks:* 100**Read the following instructions carefully.**

1. Do not open the seal of the Question Booklet until you are asked to do so by the invigilator.
2. Take out the **Optical Response Sheet (ORS)** from this Question Booklet **without breaking the seal** and read the instructions printed on the ORS carefully. If you find that either:
  - a. The Question Booklet Code printed at the right hand top corner of this page does not match with the Question Booklet Code at the right hand top corner of the **ORS** or
  - b. The Question Paper Code preceding the Registration number on the **ORS** is not **IN**, then exchange the booklet immediately with a new sealed Question Booklet.
3. On the right hand side of the **ORS**, using **ONLY a black ink ballpoint pen**, (i) darken the appropriate bubble under each digit of your registration number and (ii) write your registration number, your name and name of the examination centre and put your signature at the specified location.
4. This Question Booklet contains **20** pages including blank pages for rough work. After you are permitted to open the seal, check all pages and report discrepancies, if any, to the invigilator.
5. There are a total of 65 questions carrying 100 marks. All these questions are of objective type. Each question has only **one** correct answer. Questions must be answered on the left hand side of the **ORS** by darkening the appropriate bubble (marked A, B, C, D) using **ONLY a black ink ballpoint pen** against the question number. **For each question darken the bubble of the correct answer.** More than one answer bubbled against a question will be treated as an incorrect response.
6. Since bubbles darkened by the black ink ballpoint pen **cannot** be erased, candidates should darken the bubbles in the ORS **very carefully**.
7. Questions Q.1 – Q.25 carry 1 mark each. Questions Q.26 – Q.55 carry 2 marks each. The 2 marks questions include two pairs of common data questions and two pairs of linked answer questions. The answer to the second question of the linked answer questions depends on the answer to the first question of the pair. If the first question in the linked pair is wrongly answered or is not attempted, then the answer to the second question in the pair will not be evaluated.
8. Questions Q.56 – Q.65 belong to General Aptitude (GA) section and carry a total of 15 marks. Questions Q.56 – Q.60 carry 1 mark each, and questions Q.61 – Q.65 carry 2 marks each.
9. Questions not attempted will result in zero mark and wrong answers will result in **NEGATIVE** marks. For all 1 mark questions,  $\frac{1}{2}$  mark will be deducted for each wrong answer. For all 2 marks questions,  $\frac{2}{3}$  mark will be deducted for each wrong answer. However, in the case of the linked answer question pair, there will be negative marks only for wrong answer to the first question and no negative marks for wrong answer to the second question.
10. Calculator is allowed whereas charts, graph sheets or tables are **NOT** allowed in the examination hall.
11. Rough work can be done on the Question Booklet itself. Blank pages are provided at the end of the Question Booklet for rough work.
12. Before the start of the examination, write your name and registration number in the space provided below using a black ink ballpoint pen.

<b>Name</b>									
<b>Registration Number</b>	<b>IN</b>								

**Q.1 to Q.25 carry one mark each.**

- Q.1 The discrete-time transfer function  $\frac{1-2z^{-1}}{1-0.5z^{-1}}$  is
- (A) non-minimum phase and unstable.  
 (B) minimum phase and unstable.  
 (C) minimum phase and stable.  
 (D) non-minimum phase and stable.
- Q.2 The type of the partial differential equation  $\frac{\partial f}{\partial t} = \frac{\partial^2 f}{\partial x^2}$  is
- (A) Parabolic                      (B) Elliptic                      (C) Hyperbolic                      (D) Nonlinear
- Q.3 Match the following biomedical instrumentation techniques with their applications
- |                              |                                    |
|------------------------------|------------------------------------|
| P : Otoscopy                 | U : Respiratory volume measurement |
| Q : Ultrasound Technique     | V : Ear diagnostics                |
| R : Spirometry               | W : Echo-cardiography              |
| S : Thermodilution Technique | X : Heart volume measurement       |
- (A) P-U, Q-V, R-X, S-W                      (B) P-V, Q-U, R-X, S-W  
 (C) P-V, Q-W, R-U, S-X                      (D) P-V, Q-W, R-X, S-U
- Q.4 A continuous random variable  $X$  has a probability density function  $f(x) = e^{-x}$ ,  $0 < x < \infty$ . Then  $P\{X > 1\}$  is
- (A) 0.368                      (B) 0.5                      (C) 0.632                      (D) 1.0
- Q.5 A band-limited signal with a maximum frequency of 5 kHz is to be sampled. According to the sampling theorem, the sampling frequency in kHz which is not valid is
- (A) 5                      (B) 12                      (C) 15                      (D) 20
- Q.6 The differential pressure transmitter of a flow meter using a venturi tube reads  $2.5 \times 10^5$  Pa for a flow rate of  $0.5 \text{ m}^3/\text{s}$ . The approximate flow rate in  $\text{m}^3/\text{s}$  for a differential pressure  $0.9 \times 10^5$  Pa is
- (A) 0.30                      (B) 0.18                      (C) 0.83                      (D) 0.60
- Q.7 A bulb in a staircase has two switches, one switch being at the ground floor and the other one at the first floor. The bulb can be turned ON and also can be turned OFF by any one of the switches irrespective of the state of the other switch. The logic of switching of the bulb resembles
- (A) an AND gate                      (B) an OR gate                      (C) an XOR gate                      (D) a NAND gate
- Q.8 The impulse response of a system is  $h(t) = t u(t)$ . For an input  $u(t-1)$ , the output is
- (A)  $\frac{t^2}{2} u(t)$                       (B)  $\frac{t(t-1)}{2} u(t-1)$                       (C)  $\frac{(t-1)^2}{2} u(t-1)$                       (D)  $\frac{t^2-1}{2} u(t-1)$

- Q.9 Consider a delta connection of resistors and its equivalent star connection as shown. If all elements of the delta connection are scaled by a factor  $k$ ,  $k > 0$ , the elements of the corresponding star equivalent will be scaled by a factor of



- (A)  $k^2$                       (B)  $k$                       (C)  $1/k$                       (D)  $\sqrt{k}$
- Q.10 An accelerometer has input range of 0 to 10g, natural frequency 30 Hz and mass 0.001 kg. The range of the secondary displacement transducer in mm required to cover the input range is  
 (A) 0 to 2.76                      (B) 0 to 9.81                      (C) 0 to 11.20                      (D) 0 to 52.10
- Q.11 In the circuit shown below what is the output voltage ( $V_{out}$ ) in Volts if a silicon transistor Q and an ideal op-amp are used?

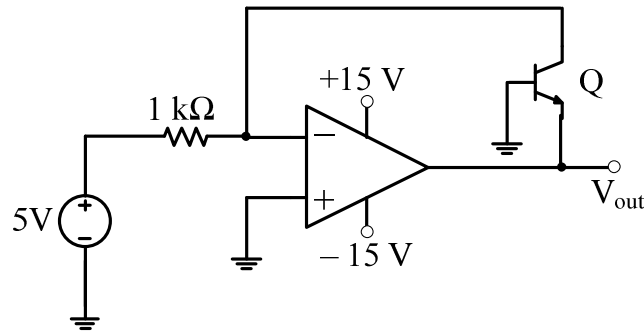

- (A)  $-15$                       (B)  $-0.7$                       (C)  $+0.7$                       (D)  $+15$
- Q.12 The Bode plot of a transfer function  $G(s)$  is shown in the figure below.

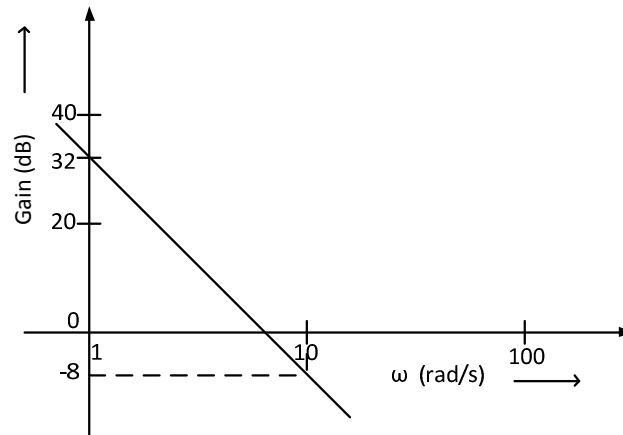

The gain ( $20 \log|G(s)|$ ) is 32 dB and  $-8$  dB at 1 rad/s and 10 rad/s respectively. The phase is negative for all  $\omega$ . Then  $G(s)$  is

- (A)  $\frac{39.8}{s}$                       (B)  $\frac{39.8}{s^2}$                       (C)  $\frac{32}{s}$                       (D)  $\frac{32}{s^2}$

Q.13 In the feedback network shown below, if the feedback factor  $k$  is increased, then the

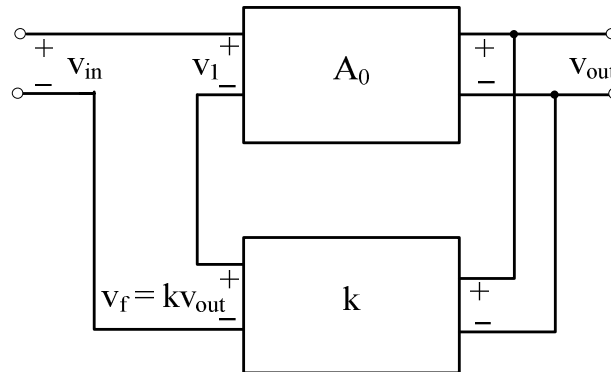

- (A) input impedance increases and output impedance decreases  
 (B) input impedance increases and output impedance also increases  
 (C) input impedance decreases and output impedance also decreases  
 (D) input impedance decreases and output impedance increases

Q.14 The dimension of the null space of the matrix  $\begin{bmatrix} 0 & 1 & 1 \\ 1 & -1 & 0 \\ -1 & 0 & -1 \end{bmatrix}$  is

- (A) 0                      (B) 1                      (C) 2                      (D) 3

Q.15 If the A-matrix of the state space model of a SISO linear time invariant system is rank deficient, the transfer function of the system must have

- (A) a pole with a positive real part  
 (B) a pole with a negative real part  
 (C) a pole with a positive imaginary part  
 (D) a pole at the origin

Q.16 Two systems with impulse responses  $h_1(t)$  and  $h_2(t)$  are connected in cascade. Then the overall impulse response of the cascaded system is given by

- (A) product of  $h_1(t)$  and  $h_2(t)$                       (B) sum of  $h_1(t)$  and  $h_2(t)$   
 (C) convolution of  $h_1(t)$  and  $h_2(t)$                       (D) subtraction of  $h_2(t)$  from  $h_1(t)$

Q.17 The complex function  $\tanh(s)$  is analytic over a region of the imaginary axis of the complex  $s$ -plane if the following is **TRUE** everywhere in the region for all integers  $n$

- (A)  $Re(s) = 0$                       (B)  $Im(s) \neq n\pi$   
 (C)  $Im(s) \neq \frac{n\pi}{3}$                       (D)  $Im(s) \neq \frac{(2n+1)\pi}{2}$

Q.18 For a vector  $\mathbf{E}$ , which one of the following statements is **NOT TRUE**?

- (A) If  $\nabla \cdot \mathbf{E} = 0$ ,  $\mathbf{E}$  is called solenoidal.  
 (B) If  $\nabla \times \mathbf{E} = 0$ ,  $\mathbf{E}$  is called conservative.  
 (C) If  $\nabla \times \mathbf{E} = 0$ ,  $\mathbf{E}$  is called irrotational.  
 (D) If  $\nabla \cdot \mathbf{E} = 0$ ,  $\mathbf{E}$  is called irrotational.

Q.19 For a periodic signal  $v(t) = 30\sin 100t + 10\cos 300t + 6\sin(500t + \pi/4)$ , the fundamental frequency in rad/s is

- (A) 100                      (B) 300                      (C) 500                      (D) 1500

Q.20 In the transistor circuit as shown below, the value of resistance  $R_E$  in  $k\Omega$  is approximately,

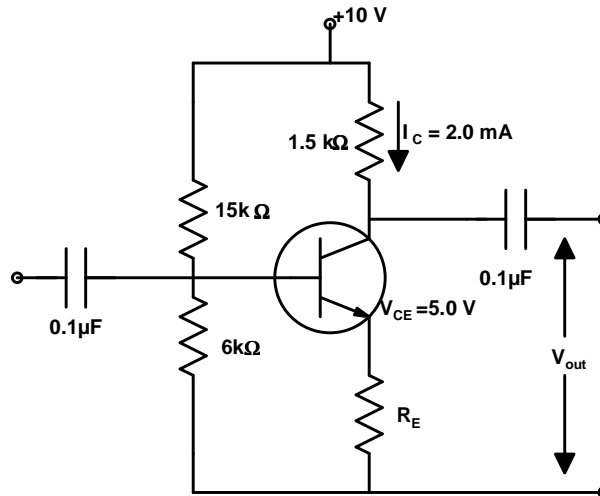

- (A) 1.0                      (B) 1.5                      (C) 2.0                      (D) 2.5

Q.21 A source  $v_s(t) = V \cos 100\pi t$  has an internal impedance of  $4 + j3 \Omega$ . If a purely resistive load connected to this source has to extract the maximum power out of the source, its value in  $\Omega$  should be

- (A) 3                      (B) 4                      (C) 5                      (D) 7

Q.22 Which one of the following statements is NOT TRUE for a continuous time causal and stable LTI system?

- (A) All the poles of the system must lie on the left side of the  $j\omega$  axis.  
 (B) Zeros of the system can lie anywhere in the  $s$ -plane.  
 (C) All the poles must lie within  $|s| = 1$ .  
 (D) All the roots of the characteristic equation must be located on the left side of the  $j\omega$  axis.

- Q.23 The operational amplifier shown in the circuit below has a slew rate of  $0.8 \text{ Volts}/\mu\text{s}$ . The input signal is  $0.25 \sin(\omega t)$ . The maximum frequency of input in kHz for which there is no distortion in the output is

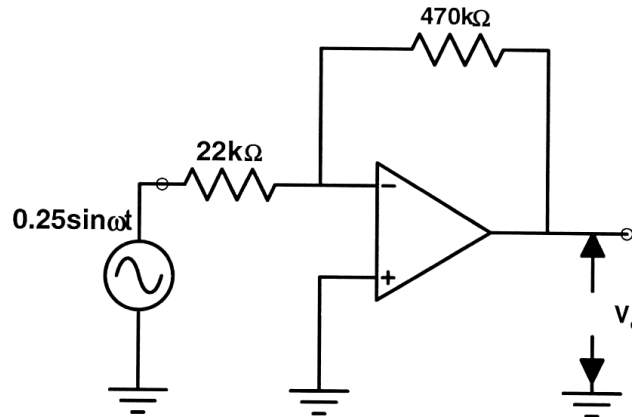

- (A) 23.84      (B) 25.0      (C) 50.0      (D) 46.60
- Q.24 Assuming zero initial condition, the response  $y(t)$  of the system given below to a unit step input  $u(t)$  is

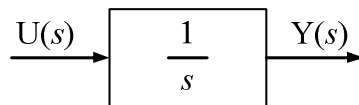

- (A)  $u(t)$       (B)  $tu(t)$       (C)  $\frac{t^2}{2}u(t)$       (D)  $e^{-t}u(t)$
- Q.25 The transfer function  $\frac{V_2(s)}{V_1(s)}$  of the circuit shown below is

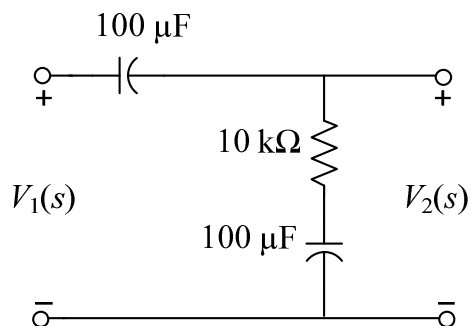

- (A)  $\frac{0.5s+1}{s+1}$       (B)  $\frac{3s+6}{s+2}$       (C)  $\frac{s+2}{s+1}$       (D)  $\frac{s+1}{s+2}$

**Q.26 to Q.55 carry two marks each.**

Q.26 The maximum value of the solution  $y(t)$  of the differential equation  $y(t) + \ddot{y}(t) = 0$  with initial conditions  $\dot{y}(0) = 1$  and  $y(0) = 1$ , for  $t \geq 0$  is

- (A) 1                      (B) 2                      (C)  $\pi$                       (D)  $\sqrt{2}$

Q.27 The Laplace Transform representation of the triangular pulse shown below is

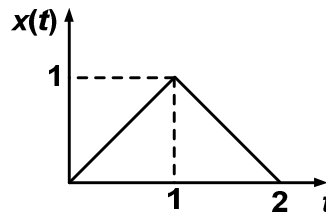

- (A)  $\frac{1}{s^2} [1 + e^{-2s}]$                       (B)  $\frac{1}{s^2} [1 - e^{-s} + e^{-2s}]$   
 (C)  $\frac{1}{s^2} [1 - e^{-s} + 2e^{-2s}]$                       (D)  $\frac{1}{s^2} [1 - 2e^{-s} + e^{-2s}]$

Q.28 In the circuit shown below, if the source voltage  $V_s = 100 \angle 53.13^\circ$  Volts, then the Thevenin's equivalent voltage in Volts as seen by the load resistance  $R_L$  is

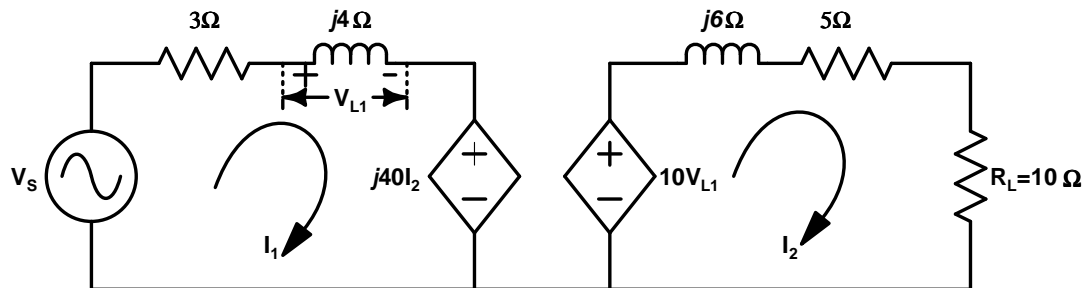

- (A)  $100 \angle 90^\circ$                       (B)  $800 \angle 0^\circ$                       (C)  $800 \angle 90^\circ$                       (D)  $100 \angle 60^\circ$



Q.29 A signal  $V_i(t) = 10 + 10 \sin 100 \pi t + 10 \sin 4000 \pi t + 10 \sin 100000 \pi t$  is supplied to a filter circuit (shown below) made up of ideal op-amps. The least attenuated frequency component in the output will be

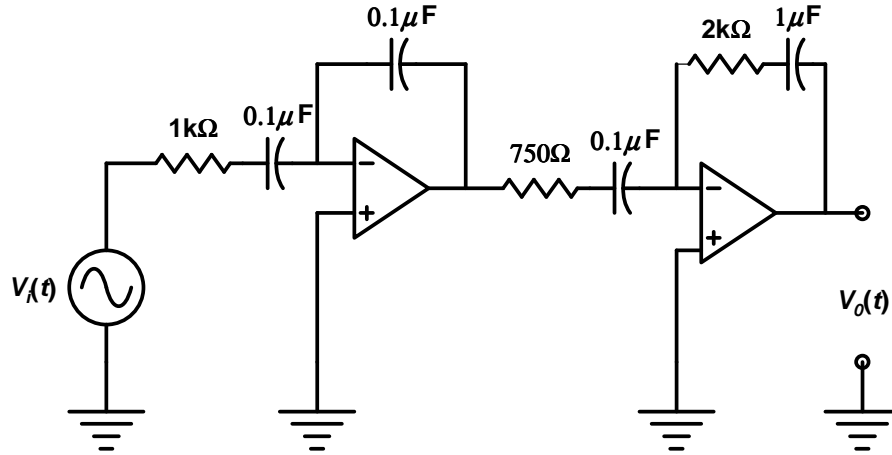

- (A) 0 Hz                      (B) 50 Hz                      (C) 2 kHz                      (D) 50 kHz

Q.30 The signal flow graph for a system is given below. The transfer function  $\frac{Y(s)}{U(s)}$  for this system is given as

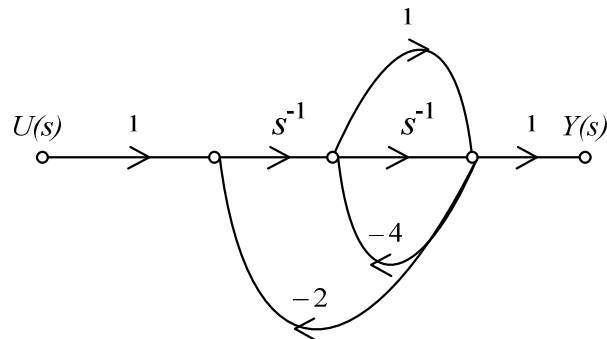

- (A)  $\frac{s+1}{5s^2+6s+2}$                       (B)  $\frac{s+1}{s^2+6s+2}$   
 (C)  $\frac{s+1}{s^2+4s+2}$                       (D)  $\frac{1}{5s^2+6s+2}$

Q.31 A voltage  $1000 \sin \omega t$  Volts is applied across YZ. Assuming ideal diodes, the voltage measured across WX in Volts, is

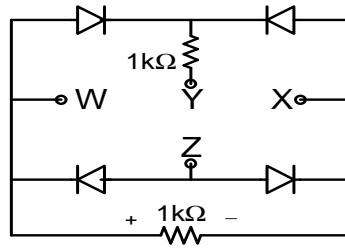

- (A)  $\sin \omega t$
- (B)  $(\sin \omega t + |\sin \omega t|)/2$
- (C)  $(\sin \omega t - |\sin \omega t|)/2$
- (D) 0 for all  $t$

Q.32 In the circuit shown below the op-amps are ideal. Then  $V_{out}$  in Volts is

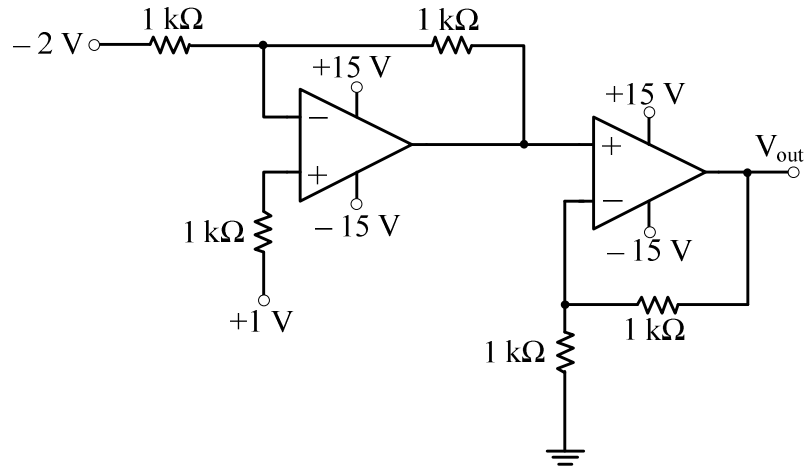

- (A) 4
- (B) 6
- (C) 8
- (D) 10

Q.33 In the circuit shown below,  $Q_1$  has negligible collector-to-emitter saturation voltage and the diode drops negligible voltage across it under forward bias. If  $V_{cc}$  is +5 V, X and Y are digital signals with 0 V as logic 0 and  $V_{cc}$  as logic 1, then the Boolean expression for Z is

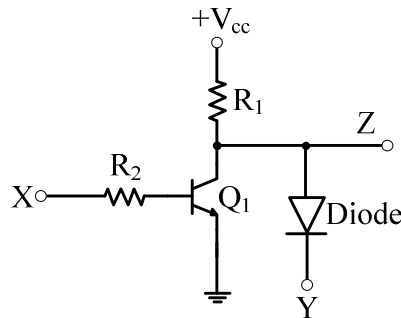

- (A)  $XY$
- (B)  $\bar{X}Y$
- (C)  $X\bar{Y}$
- (D)  $\bar{X}\bar{Y}$

- Q.34 The circuit below incorporates a permanent magnet moving coil milli-ammeter of range  $1\text{ mA}$  having a series resistance of  $10\text{ k}\Omega$ . Assuming constant diode forward resistance of  $50\ \Omega$ , a forward diode drop of  $0.7\text{ V}$  and infinite reverse diode resistance for each diode, the reading of the meter in  $\text{mA}$  is

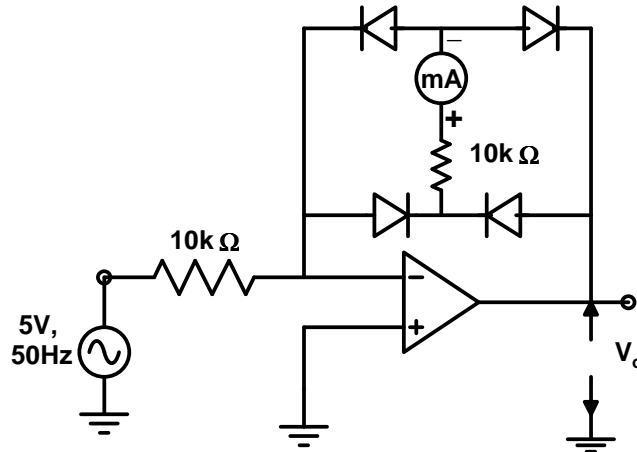

- (A) 0.45                      (B) 0.5                      (C) 0.7                      (D) 0.9

- Q.35 Two ammeters  $A_1$  and  $A_2$  measure the same current and provide readings  $I_1$  and  $I_2$ , respectively. The ammeter errors can be characterized as independent zero mean Gaussian random variables of standard deviations  $\sigma_1$  and  $\sigma_2$ , respectively. The value of the current is computed as :

$$I = \mu I_1 + (1 - \mu) I_2$$

The value of  $\mu$  which gives the lowest standard deviation of  $I$  is

- (A)  $\frac{\sigma_2^2}{\sigma_1^2 + \sigma_2^2}$                       (B)  $\frac{\sigma_1^2}{\sigma_1^2 + \sigma_2^2}$                       (C)  $\frac{\sigma_2}{\sigma_1 + \sigma_2}$                       (D)  $\frac{\sigma_1}{\sigma_1 + \sigma_2}$

- Q.36 Measurement of optical absorption of a solution is disturbed by the additional stray light falling at the photo-detector. For estimation of the error caused by stray light the following data could be obtained from controlled experiments.

Photo-detector output without solution and without stray light is  $500\ \mu\text{W}$ .

Photo-detector output without solution and with stray light is  $600\ \mu\text{W}$ .

Photo-detector output with solution and with stray light is  $200\ \mu\text{W}$ .

The percent error in computing absorption coefficient due to stray light is

- (A) 12.50                      (B) 31.66                      (C) 33.33                      (D) 94.98

- Q.37 One pair of eigenvectors corresponding to the two eigenvalues of the matrix  $\begin{bmatrix} 0 & -1 \\ 1 & 0 \end{bmatrix}$  is

- (A)  $\begin{bmatrix} 1 \\ -j \end{bmatrix}, \begin{bmatrix} j \\ -1 \end{bmatrix}$                       (B)  $\begin{bmatrix} 0 \\ 1 \end{bmatrix}, \begin{bmatrix} -1 \\ 0 \end{bmatrix}$                       (C)  $\begin{bmatrix} 1 \\ j \end{bmatrix}, \begin{bmatrix} 0 \\ 1 \end{bmatrix}$                       (D)  $\begin{bmatrix} 1 \\ j \end{bmatrix}, \begin{bmatrix} j \\ 1 \end{bmatrix}$

Q.38 While numerically solving the differential equation  $\frac{dy}{dx} + 2xy^2 = 0$ ,  $y(0) = 1$  using Euler's predictor-corrector (improved Euler-Cauchy) method with a step size of 0.2, the value of  $y$  after the first step is

- (A) 1.00                      (B) 1.03                      (C) 0.97                      (D) 0.96

Q.39 The digital circuit shown below uses two negative edge-triggered D-flip-flops. Assuming initial condition of  $Q_1$  and  $Q_0$  as zero, the output  $Q_1Q_0$  of this circuit is

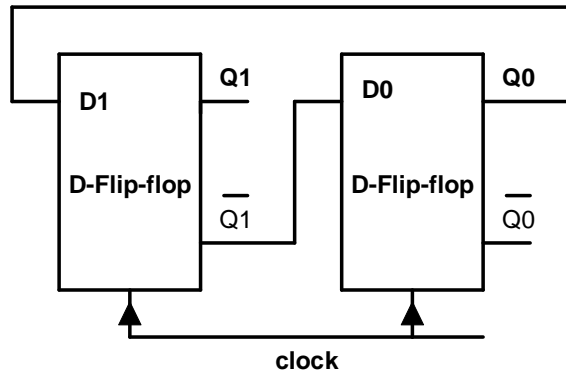

- (A) 00,01,10,11,00 ...  
 (B) 00,01,11,10,00 ...  
 (C) 00,11,10,01,00 ...  
 (D) 00,01,11,11,00 ...

Q.40 Considering the transformer to be ideal, the transmission parameter 'A' of the 2-port network shown in the figure below is

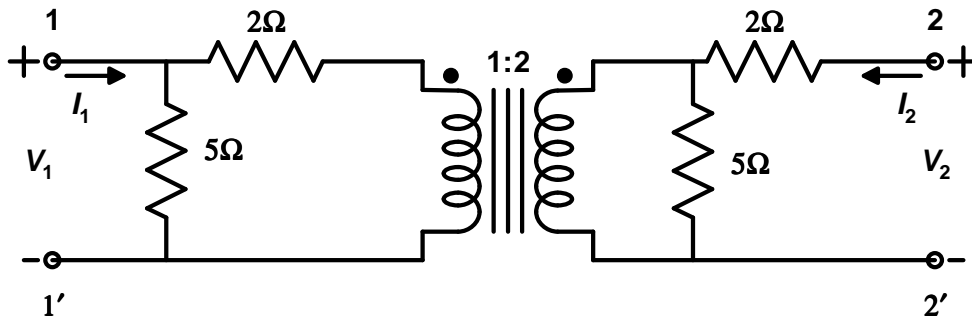

- (A) 1.3                      (B) 1.4                      (C) 0.5                      (D) 2.0

- Q.41 The following arrangement consists of an ideal transformer and an attenuator, which attenuates by a factor of 0.8. An ac voltage  $V_{WX1} = 100\text{V}$  is applied across WX to get an open circuit voltage  $V_{YZ1}$  across YZ. Next, an ac voltage  $V_{YZ2} = 100\text{V}$  is applied across YZ to get an open circuit voltage  $V_{WX2}$  across WX. Then,  $V_{YZ1}/V_{WX1}$ ,  $V_{WX2}/V_{YZ2}$  are respectively,

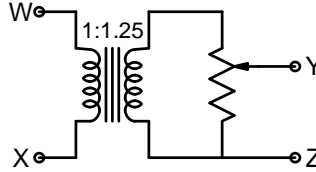

- (A) 125/100 and 80/100  
 (B) 100/100 and 80/100  
 (C) 100/100 and 100/100  
 (D) 80/100 and 80/100
- Q.42 The open-loop transfer function of a dc motor is given as  $\frac{\omega(s)}{V_a(s)} = \frac{10}{1+10s}$ . When connected in feedback as shown below, the approximate value of  $K_a$  that will reduce the time constant of the closed loop system by one hundred times as compared to that of the open-loop system is

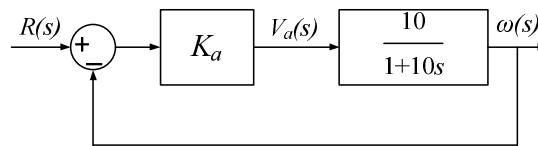

- (A) 1  
 (B) 5  
 (C) 10  
 (D) 100
- Q.43 Two magnetically uncoupled inductive coils have  $Q$  factors  $q_1$  and  $q_2$  at the chosen operating frequency. Their respective resistances are  $R_1$  and  $R_2$ . When connected in series, the effective  $Q$  factor of the series combination at the same operating frequency is
- (A)  $q_1 + q_2$   
 (B)  $(1/q_1) + (1/q_2)$   
 (C)  $(q_1 R_1 + q_2 R_2) / (R_1 + R_2)$   
 (D)  $(q_1 R_2 + q_2 R_1) / (R_1 + R_2)$
- Q.44 For the circuit shown below, the knee current of the ideal Zener diode is 10 mA. To maintain 5 V across  $R_L$ , the minimum value of the load resistor  $R_L$  in  $\Omega$  and the minimum power rating of the Zener diode in mW, respectively, are

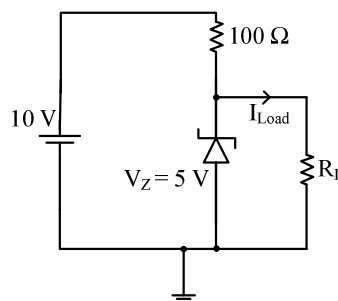

- (A) 125 and 125  
 (B) 125 and 250  
 (C) 250 and 125  
 (D) 250 and 250
- Q.45 The impulse response of a continuous time system is given by  $h(t) = \delta(t-1) + \delta(t-3)$ . The value of the step response at  $t = 2$  is
- (A) 0  
 (B) 1  
 (C) 2  
 (D) 3

- Q.46 Signals from fifteen thermocouples are multiplexed and each one is sampled once per second with a 16-bit ADC. The digital samples are converted by a parallel to serial converter to generate a serial PCM signal. This PCM signal is frequency modulated with FSK modulator with 1200 Hz as 1 and 960 Hz as 0. The minimum band allocation required for faithful reproduction of the signal by the FSK receiver without considering noise is
- (A) 840 Hz to 1320 Hz (B) 960 Hz to 1200 Hz  
(C) 1080 Hz to 1320 Hz (D) 720 Hz to 1440 Hz
- Q.47 Three capacitors  $C_1$ ,  $C_2$  and  $C_3$  whose values are  $10\mu\text{F}$ ,  $5\mu\text{F}$ , and  $2\mu\text{F}$  respectively, have breakdown voltages of 10V, 5V, and 2V respectively. For the interconnection shown below, the maximum safe voltage in Volts that can be applied across the combination, and the corresponding total charge in  $\mu\text{C}$  stored in the effective capacitance across the terminals are, respectively,

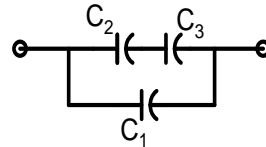

- (A) 2.8 and 36 (B) 7 and 119  
(C) 2.8 and 32 (D) 7 and 80

### Common Data Questions

#### Common Data for Questions 48 and 49:

A piezo-electric force sensor, connected by a cable to a voltage amplifier, has the following parameters :

Crystal properties : Stiffness  $10^9 \text{ N/m}$ , Damping ratio 0.01, Natural frequency  $10^5 \text{ rad/s}$ , Force-to-Charge sensitivity  $10^{-9} \text{ C/N}$ , Capacitance  $10^{-9} \text{ F}$  with its loss angle assumed negligible

Cable properties : Capacitance  $2 \times 10^{-9} \text{ F}$  with its resistance assumed negligible

Amplifier properties : Input impedance  $1 \text{ M}\Omega$ , Bandwidth  $1 \text{ MHz}$ , Gain 3

- Q.48 The maximum frequency of a force signal in Hz below the natural frequency within its useful mid-band range of measurement, for which the gain amplitude is less than 1.05, approximately is,
- (A) 35 (B) 350 (C) 3500 (D)  $16 \times 10^3$
- Q.49 The minimum frequency of a force signal in Hz within its useful mid-band range of measurement, for which the gain amplitude is more than 0.95, approximately is,
- (A) 16 (B) 160 (C) 1600 (D)  $16 \times 10^3$

#### Common Data for Questions 50 and 51:

A tungsten wire used in a constant current hot wire anemometer has the following parameters :

Resistance at  $0^\circ \text{ C}$  is  $10\Omega$ , Surface area is  $10^{-4} \text{ m}^2$ , Linear temperature coefficient of resistance of the tungsten wire is  $4.8 \times 10^{-3} / ^\circ\text{C}$ , Convective heat transfer coefficient is  $25.2 \text{ W} / \text{m}^2 / ^\circ\text{C}$ , flowing air temperature is  $30^\circ\text{C}$ , wire current is  $100 \text{ mA}$ , mass-specific heat product is  $2.5 \times 10^{-5} \text{ J} / ^\circ\text{C}$

- Q.50 The thermal time constant of the hot wire under flowing air condition in  $\text{ms}$  is
- (A) 24.5 (B) 12.25 (C) 6.125 (D) 3.0625
- Q.51 At steady state, the resistance of the wire in  $\Omega$  is
- (A) 10.000 (B) 10.144 (C) 12.152 (D) 14.128

## Linked Answer Questions

### Statement for Linked Answer Questions 52 and 53:

A differential amplifier with signal terminals X,Y,Z is connected as shown in Fig. (a) below for CMRR measurement where the differential amplifier has an additional constant offset voltage in the output. The observations obtained are: when  $V_i = 2V$ ,  $V_o = 3mV$ , and when  $V_i = 3V$ ,  $V_o = 4mV$ .

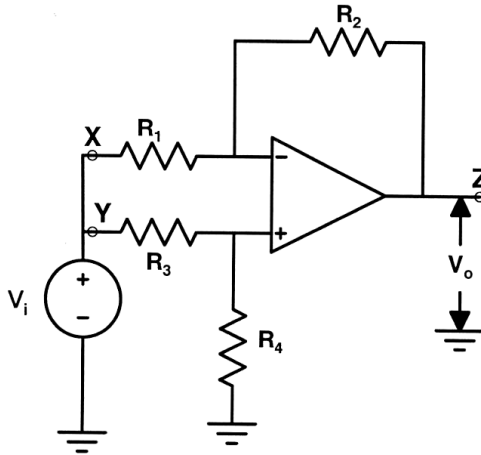

Fig. (a)

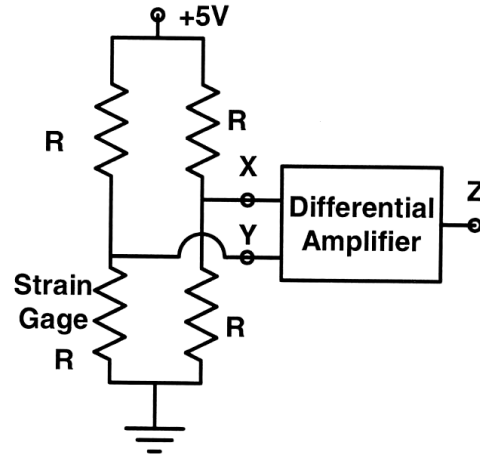

Fig. (b)

- Q.52 Assuming its differential gain to be 10 and the op-amp to be otherwise ideal, the CMRR is  
 (A)  $10^2$  (B)  $10^3$  (C)  $10^4$  (D)  $10^5$
- Q.53 The differential amplifier is connected as shown in Fig. (b) above to a single strain gage bridge. Let the strain gage resistance vary around its no-load resistance  $R$  by  $\pm 1\%$ . Assume the input impedance of the amplifier to be high compared to the equivalent source resistance of the bridge, and the common mode characteristic to be as obtained above. The output voltage in  $mV$  varies approximately from  
 (A) +128 to -128 (B) +128 to -122 (C) +122 to -122 (D) +99 to -101

### Statement for Linked Answer Questions 54 and 55:

Consider a plant with the transfer function  $G(s) = 1/(s+1)^3$ . Let  $K_u$  and  $T_u$  be the ultimate gain and ultimate period corresponding to the frequency response based closed loop Ziegler-Nichols cycling method, respectively. The Ziegler-Nichols tuning rule for a P-controller is given as :  $K = 0.5 K_u$ .

- Q.54 The values of  $K_u$  and  $T_u$ , respectively, are  
 (A)  $2\sqrt{2}$  and  $2\pi$  (B) 8 and  $2\pi$  (C) 8 and  $2\pi/\sqrt{3}$  (D)  $2\sqrt{2}$  and  $2\pi/\sqrt{3}$
- Q.55 The gain of the transfer function between the plant output and an additive load disturbance input of frequency  $2\pi/T_u$  in closed loop with a P-controller designed according to the Ziegler-Nichols tuning rule as given above is  
 (A) -1.0 (B) 0.5 (C) 1.0 (D) 2.0

## General Aptitude (GA) Questions

### Q.56 to Q.60 carry one mark each.

Q.56 Choose the grammatically **CORRECT** sentence:

- (A) Two and two add four.
- (B) Two and two become four.
- (C) Two and two are four.
- (D) Two and two make four.

Q.57 **Statement:** You can always give me a ring whenever you need.

Which one of the following is the best inference from the above statement?

- (A) Because I have a nice caller tune.
- (B) Because I have a better telephone facility.
- (C) Because a friend in need is a friend indeed.
- (D) Because you need not pay towards the telephone bills when you give me a ring.

Q.58 In the summer of 2012, in New Delhi, the mean temperature of Monday to Wednesday was 41°C and of Tuesday to Thursday was 43°C. If the temperature on Thursday was 15% higher than that of Monday, then the temperature in °C on Thursday was

- (A) 40
- (B) 43
- (C) 46
- (D) 49

Q.59 Complete the sentence:

Dare \_\_\_\_\_ mistakes.

- (A) commit
- (B) to commit
- (C) committed
- (D) committing

Q.60 They were requested not to **quarrel** with others.

Which one of the following options is the closest in meaning to the word **quarrel**?

- (A) make out
- (B) call out
- (C) dig out
- (D) fall out

### Q.61 to Q.65 carry two marks each.

Q.61 A car travels 8 km in the first quarter of an hour, 6 km in the second quarter and 16 km in the third quarter. The average speed of the car in km per hour over the entire journey is

- (A) 30
- (B) 36
- (C) 40
- (D) 24

Q.62 Find the sum to  $n$  terms of the series  $10+84+ 734 + \dots$

- (A)  $\frac{9(9^n + 1)}{10} + 1$
- (B)  $\frac{9(9^n - 1)}{8} + 1$
- (C)  $\frac{9(9^n - 1)}{8} + n$
- (D)  $\frac{9(9^n - 1)}{8} + n^2$



Q.63 **Statement:** There were different streams of freedom movements in colonial India carried out by the moderates, liberals, radicals, socialists, and so on.

Which one of the following is the best inference from the above statement?

- (A) The emergence of nationalism in colonial India led to our Independence.
- (B) Nationalism in India emerged in the context of colonialism.
- (C) Nationalism in India is homogeneous.
- (D) Nationalism in India is heterogeneous.

Q.64 The set of values of  $p$  for which the roots of the equation  $3x^2+2x+p(p-1) = 0$  are of opposite sign is

- (A)  $(-\infty, 0)$                       (B)  $(0, 1)$                       (C)  $(1, \infty)$                       (D)  $(0, \infty)$

Q.65 What is the chance that a leap year, selected at random, will contain 53 Saturdays?

- (A)  $2/7$                       (B)  $3/7$                       (C)  $1/7$                       (D)  $5/7$

**END OF THE QUESTION PAPER**